

Mounting instructions

Screw compressor
SiloKing 700 / 1100 / 1500
SiloKing 700 / 110 LS



Doc-ID: 5068 / MA / EN

Release: Rev. 02 / 17/03/2020

Prior to installing the SiloKing and putting it into operation you must have read and understood these instructions. These instructions are only valid together with the operating instructions, they do not replace them!

Translation of the Original Assembly Instructions

© CVS engineering GmbH

Großmattstraße 14
79618 Rheinfeldern / Germany

Phone: +49 (0)7623 71741-0
Customer service: +49 (0)7623 71741-0
E-Mail: info@cvs-eng.de
Internet: www.cvs-eng.de



1	General	5
1.1	Information on the assembly instructions	5
1.2	Pictogram explanation	6
1.3	Limitation of Liability	7
1.4	Copyright protection.....	7
1.5	Spare parts	7
1.6	Warranty conditions	7
1.7	Customer Service	7
1.8	EC Declaration of Incorporation.....	7
2	Safety	8
2.1	Intended use	8
2.2	Acceptance and monitoring	8
2.3	Operator's responsibility	8
2.4	Requirements placed upon the specialised staff	8
2.5	Personal protective equipment	9
2.6	Occupational safety and special risks	9
3	Technical data	10
3.1	Dimensions of SiloKing.....	10
3.2	Technical data.....	13
4	Design	16
4.1	Design.....	16
4.2	Function	17
5	Transport and storage	18
5.1	Safety notes for transport	18
5.2	Transport.....	18
5.3	Storage	19
6	Installation and assembly	20
6.1	Safety.....	20
6.2	Installation.....	21
6.3	Necessary work	21
6.4	SiloKing screw compressor	22
6.5	Suction and pressure line	23
6.6	Muffler (silencer)	23
6.7	Safety equipment.....	24
6.7.1	Safety valve	24
6.7.2	Non-return valve	25
6.7.3	Suction filter.....	25
6.7.4	Protection against contact	25
6.8	Display and monitoring equipment	26
6.9	Oil cooler.....	27
6.10	Compressed air after-cooler	27

Contents

6.11	Drive	28
6.11.1	V belt drive	28
6.11.2	Articulated shaft drive	29
6.11.3	Drive via flexible coupling and hydraulic motor	29
6.11.4	Drive via adapter gear (SiloKing 700 / 1100 / 700 LS / 1100 LS)	30
7	Start-up	32
7.1	Safety during start-up	32
7.2	Start-up	32
7.3	Switching off	33
8	EC Declaration of Incorporation	34
	Index	35

1 General

1.1 Information on the assembly instructions

These assembly instructions provide important information about installation and start-up of the SiloKing. A precondition for safe operation is the observance of all specified safety and handling instructions.

Furthermore, all local accident prevention regulations and general safety regulations valid for the application area of the SiloKing must be observed.

You must have read and understood the mounting instructions before you start installing the machine and put it into operation! It is a product component and must be kept in direct proximity of the SiloKing, well accessible to the personnel at all times. All safety instructions of the operating instructions must additionally be observed.

General

1.2 Pictogram explanation

Warning notes

Warning notes are characterised by pictograms in these mounting instructions. The warning notes are marked by signal words expressing the extent of the hazard.

It is absolutely essential to observe the notes and to proceed with caution in order to prevent accidents as well as bodily injuries and property damage.



DANGER!

points to an immediately dangerous situation, which can lead to death or serious injuries if it is not avoided.



WARNING!

... points to an immediately dangerous situation, which can lead to death or serious injuries if it is not avoided.



CAUTION!

... points to a potentially dangerous situation, which can lead to minor or light injuries if it is not avoided.



ATTENTION!

... points to a potentially dangerous situation, which may lead to property damage if it is not avoided.

Hints and recommendations



NOTE!

... highlights useful hints and recommendations as well as information for an efficient and trouble-free operation.

1.3 Limitation of Liability

For information on limitation of liability, see the operating instructions "SiloKing 700 / 1100 / 1500, SiloKing 700 / 1100 LS".

1.4 Copyright protection

For information on copyright protection, see the operating instructions "SiloKing 700 / 1100 / 1500, SiloKing 700 / 1100 LS".

1.5 Spare parts

For information on spare parts see operating instructions "SiloKing 700 / 1100 / 1500, SiloKing 700 / 1100 LS".

1.6 Warranty conditions

For warranty conditions refer to the "General Terms and Conditions".

1.7 Customer Service

Our customer service can be contacted for any technical advice. Information about the responsible contact person can be retrieved by telephone, fax, E-mail or via the Internet at any time, refer to manufacturer's address on page 2.

1.8 EC Declaration of Incorporation

Declaration of incorporation (pursuant to EC Machinery Directive 2006/42/EC, Part 1, Section B, Annex II) see page 34.

Safety

2 Safety

2.1 Intended use

The screw compressors of the SiloKing model range have been developed for installation in a superordinate system. The manufacturer of the overall system must assess the new risks resulting from the installation. These risks must be included in the operating instructions of the system.

The SiloKing is intended exclusively for the compression of filtered air.

Use the SiloKing only as intended.

All information in the installation and operating instructions must be strictly observed (technical data, operating data, permissible working range, see page 13).

All types of claims due to damage arising from improper use are excluded. The operator alone shall be responsible for any damage arising from improper use.

2.2 Acceptance and monitoring

The SiloKing itself is not subject to any acceptance and monitoring obligation.

2.3 Operator's responsibility

For information on responsibility of the operator, see the operating instructions "SiloKing 700 / 1100 / 1500, SiloKing 700 / 1100 LS".

2.4 Requirements placed upon the specialised staff

The mounting instructions specify the following qualification requirements for the different fields of activity:

■ Specialists

are due to their technical training, knowledge and experience and their knowledge of the pertinent regulations able to carry out the work assigned to them and to independently recognize potential hazards.

■ Electrical specialists

are, due to their technical training, knowledge and experiences and their knowledge of the relevant standards and regulations, able to work on electrical systems and to independently recognize possible hazards.

2.5 Personal protective equipment

For information on personal protective equipment, see the operating instructions "SiloKing 700 / 1100 / 1500, SiloKing 700 / 1100 LS".

2.6 Occupational safety and special risks

Observe all safety instructions in accordance with the operating instructions "SiloKing 700 / 1100 / 1500, SiloKing 700 / 1100 LS" chapter "Occupational safety".

Technical data

3 Technical data

3.1 Dimensions of SiloKing

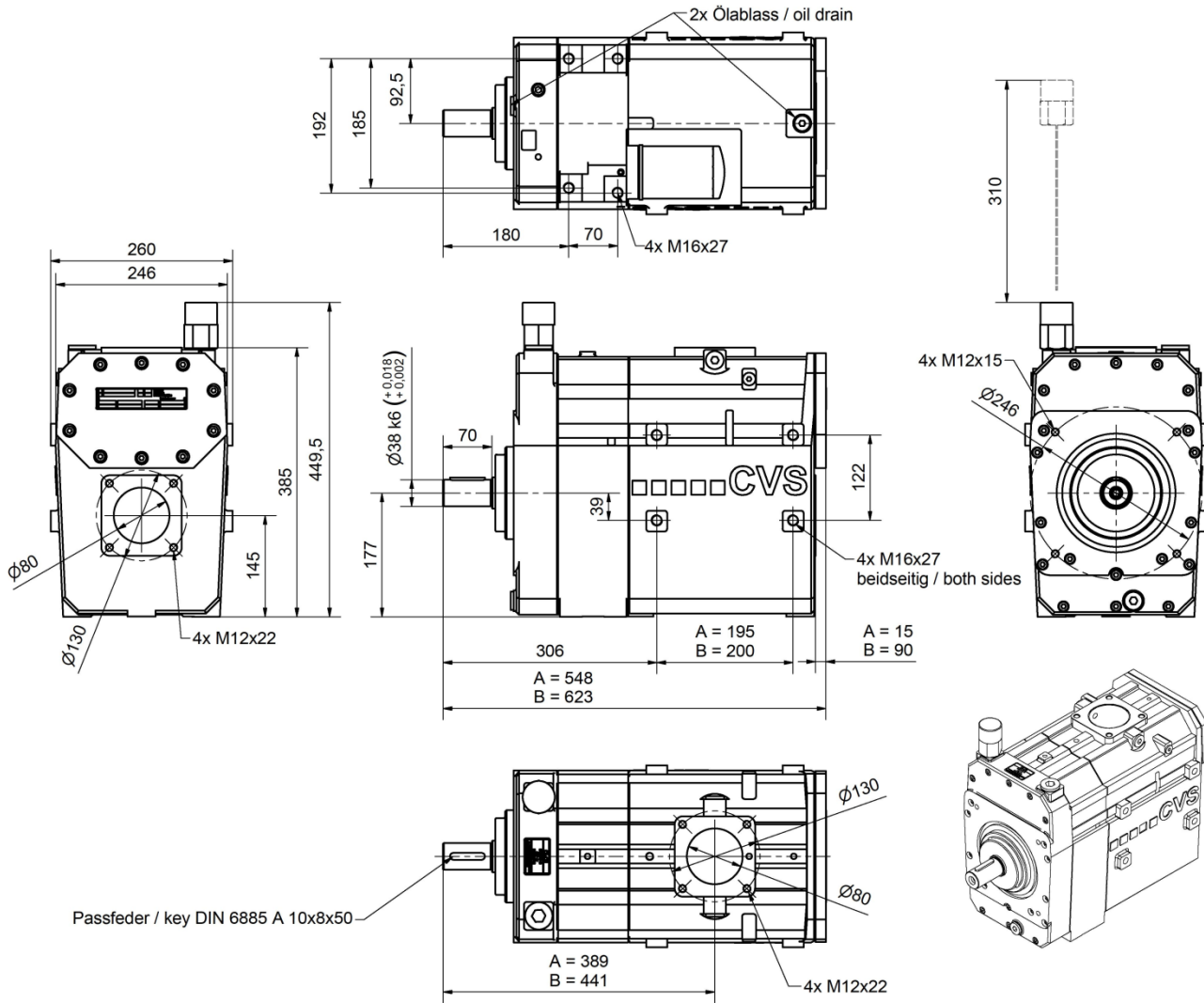

A: SiloKing 700

B: SiloKing 1100

Fig. 1: Dimensions SiloKing 700 / 1100

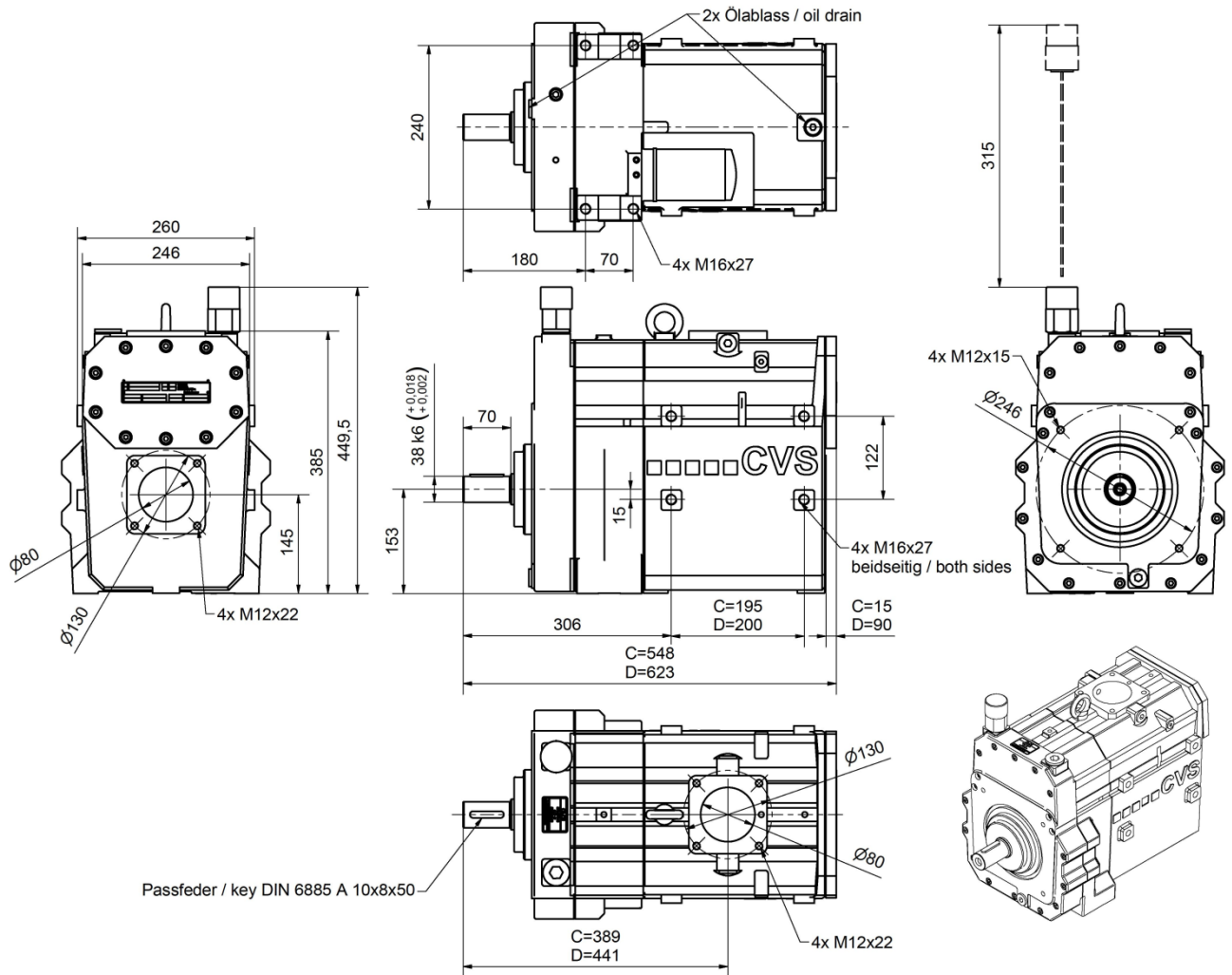

C: SiloKing 700 LS

D: SiloKing 1100 LS

Fig. 2: Dimensions SiloKing 700 LS / 1100 LS

Technical data

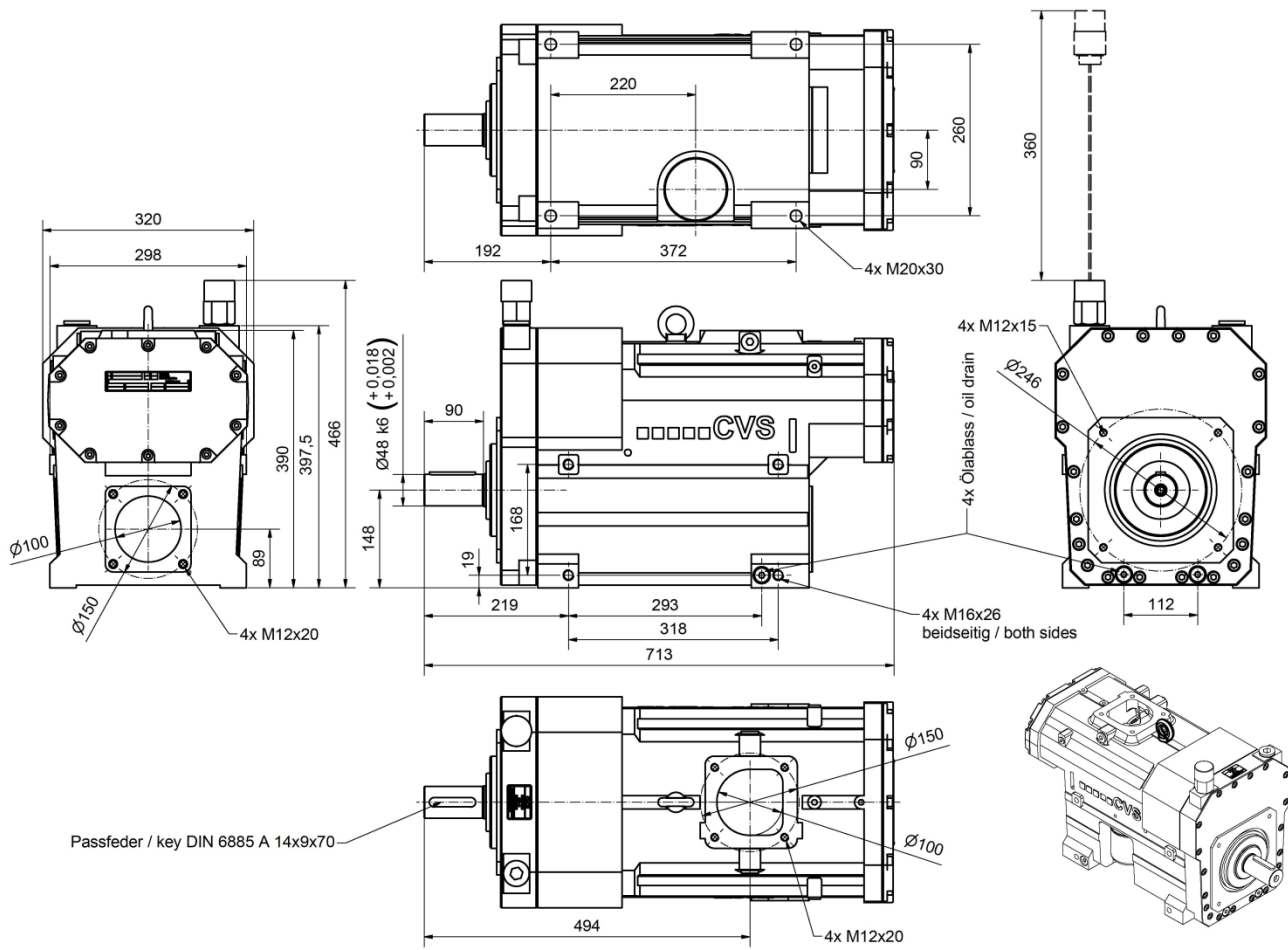

Fig. 3: Dimensions SiloKing 1500

3.2 Technical data

General data	Unit	Model 700	Model 1100	Model 700 LS	Model 1100 LS	Model 1500
Moment of inertia SiloKing	[kgm ²]	0.242	0.358	0.245	0.361	2.43
Mass moment of inertia SiloKing with adapter gear	[kgm ²]	1.044	1.51	1.056	1.52	–
Weight SiloKing	[kg]	117	127	126	135	185
Weight SiloKing with adapter gear	[kg]	157	167	166	175	–
Permissible deviation from the horizontal line	[°]	±10				±3

Tab. 1: General data

Permissible working range	Unit	Model 700	Model 1100	Model 700 LS	Model 1100 LS	Model 1500
Drive speed ⁰⁾	[min ⁻¹]	2400...3600	2000...3600	1950...2930	1630...2930	1000...2000
Suction temperature ¹⁾	[°C]	– 10...+ 40				
Geodetic height ¹⁾	[m]	0...1000				
Negative pressure suction side (e.g. due to soiling)	[mbar]	0...65				
Maximum final overpressure at the pressure flange ²⁾	[bar]	2.5				
Running time in continuous operation ³⁾	[h]	max. 3.0				

0) When an adapter gear unit is fitted, the drive speed is reduced in accordance with the transmission ratio used (see chapter 6.11.4).

1) For suction temperatures or heights outside the permissible working range, consult with CVS.

2) In case of increased suction temperatures or heights, the maximum permissible final pressure is reduced. Consult with CVS.

3) For continuous operation in excess of 3 hours, an oil cooler must be installed. Installation instructions on request.

Tab. 2: Permissible working range

Technical data

SiloKing performance characteristics ¹⁾		Unit	Model 700			Model 1100			
Input speed	SiloKing	[min ⁻¹]	2400	3000	3600	2000	2400	3000	3600
	SiloKing LS	[min ⁻¹]	1950	2440	2930	1630	1950	2440	2930
Intake volume flow at a final overpressure at the pressure flange	0.0 bar	[m ³ /h]	420	540	650	550	675	850	1050
	2.5 bar		376	471	587	475	581	756	962
Coupling power at a final overpressure at the pressure flange:	0.0 bar	[kW]	11.0	13.5	16.0	17	19.0	22.5	26.5
	2.5 bar		25.5	31.5	38.0	31	37.0	49.0	59.5
Final temperature at final overpressure = 2.0 bar		[°C]	188	184	179	191	188	184	179
max. perm. final temperature at final overpressure = 2.5bar		[°C]	250						

SiloKing performance characteristics ¹⁾		Unit	Model 1500		
Input speed		[min ⁻¹]	1000	1500	2000
Intake volume flow at a final overpressure at the pressure flange	0.0 bar	[m ³ /h]	770	1220	1640
	2.0 bar		690	1140	1560
	2.5 bar		670	1120	1540
Coupling power at a final overpressure at the pressure flange of:	0.0 bar	[kW]	14	26	40
	2.0 bar		41	62	85
	2.5 bar		48	71	96
Final temperature at final overpressure = 2.0 bar		[°C]	180	176	176
max. perm. final temperature at final overpressure = 2.5bar		[°C]	250		

1) Suction pressure at suction flange = 1.0 bar, suction and ambient temperature = 20 °C, geodetic altitude max. 1000 m

Tab. 3: Performance characteristics

Gear oil specification	Value
Specification	API CD/SF or higher
SAE viscosity class	10W40 or 15W40
Oil pressure SiloKing	min. 0.5 bar (excess pressure)
Gear oil quantity SiloKing ¹⁾	
Type 700 / 1100	8 litres
700 LS / 1100 LS	7 litres
1500	6.8 litres

Gear oil specification	Value
Gear oil quantity, adapter gear: Type 700 / 700 LS / 1100 / 1100 LS – Drive shaft top – Drive shaft right and left	1.1 litres 1.5 litres

1) When connecting a gear oil cooler, the oil quantity must be increased commensurate with the additional volume.

Tab. 4: Gear oil specification

Recommended gear oils	Brand	Type of oil
	CVS ¹⁾	CVS Lube 2000
	CVS	CVS Lebensmitteltauglich

Other oil types on request.

1) Using CVS Lube 2000 doubles the oil change interval to 1 year or 1000 operating hours respectively and extends the warranty period to 2 years.

Tab. 5: Types of gear oil

Design

4 Design

4.1 Design

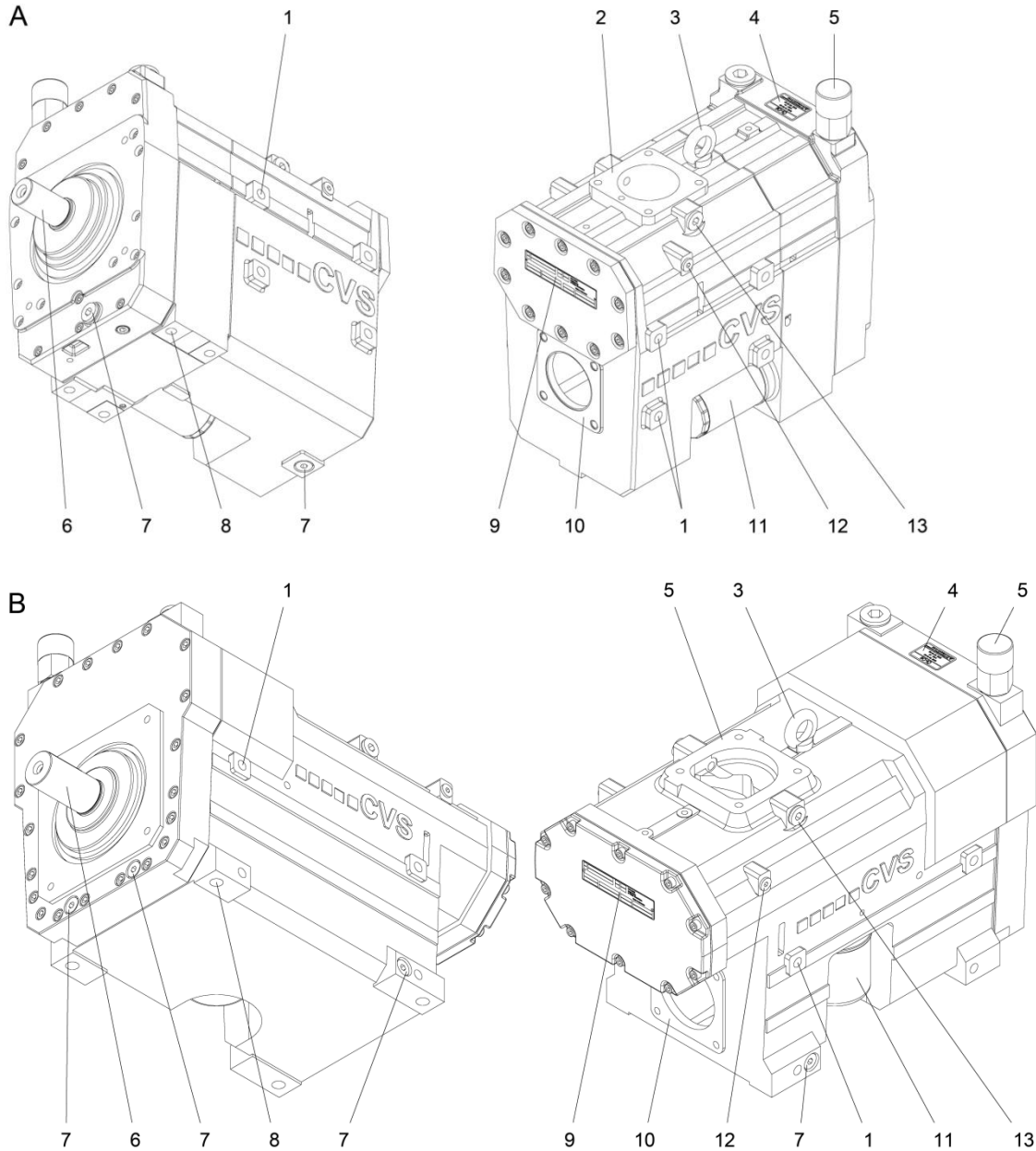

Fig. 4: View of the SiloKing and details

A: SiloKing 700 / 1100 / 700 LS / 1100 LS

B: SiloKing 1500

- | | | | | | |
|---|--|---|--|----|--|
| 1 | Attachment thread vertical (4 pieces per side of the SiloKing) | 5 | Oil filler neck cap / gearbox ventilation with oil dip stick | 9 | Rating plate data SiloKing |
| 2 | Air outlet flange | 6 | Drive shaft with feather key | 10 | Air intake flange |
| 3 | Attachment point for transport | 7 | Oil drain screw | 11 | Gear oil filter |
| 4 | Rating plate gear oil | 8 | Horizontal fastening screw thread (4 pieces) | 12 | Connection oil pressure gauge |
| | | | | 13 | Connection pressure gauge or temperature sensor for compressed air |

4.2 Function

Functional principle

Cleaned air is taken in via the air intake flange. Two screw rotors compress the air completely dry. The rotors are running contact-free both in relation to each other and to the casing. They are kept apart by a synchronising gearbox. The compressed air reaches the consumer via the air outlet flange.

Lubrication

Bearing and gearbox are supplied with gear oil via an oil filter by means of an integrated oil pump.

Cooling

The heat is dissipated to the ambient air via the casing surface.

Sense of rotation

The direction of rotation of the drive shaft is clockwise when looking at the drive shaft (SiloKing without adapter gear).

Drives

The machine is driven via coupling, V-belt or articulated shaft. For drive via PTO shaft and when installing the SiloKing inside the vehicle chassis, CVS offers an adapter gear with a transmission ratio of 1:2 or 1:2.5 (type 700 / 1100 / 700 LS / 1100 LS).

Transport and storage

5 Transport and storage

5.1 Safety notes for transport

Improper transport



Danger!
Danger by falling down or tilting of the SiloKing!

The weight of the SiloKing may injure a person and cause serious bruising!

Therefore:

- Depending on the dead weight and size of the SiloKing, use a pallet on which the SiloKing can be moved by means of a fork lift.
- For lifting the SiloKing, use suitable lifting gear (slings, etc.) that is designed for the weight of the SiloKing.
- When putting the slings in position, take care to avoid putting stress on individual components.
- Only use the provided attachment points with eye bolts.

Also observe the safety instructions in the operating instructions "SiloKing 700 / 1100 / 1500, SiloKing 700 / 1100 LS"!

5.2 Transport

The SiloKing fastened on a baseplate must be transported by means of a fork lift or suitable straps. The lifting gear must be designed for the weight of the SiloKing.

For future transports:

- Seal all open connections with protective caps (prevents penetration of dirt and water)
- Secure against vibrations
- Drain gear oil
- Securely fasten the SiloKing prior to transport (e.g. screw it onto a pallet)
- Transport and put down the SiloKing with a fork lift or secure with straps and lift with suitable lifting gear.

5.3 Storage

Storage of packages

Store packages under the following conditions:

- Do not store outdoors.
- Store dry and dust free.
- Do not expose to aggressive media.
- Protect against solar irradiation.
- Avoid mechanical vibrations.
- Storage temperature: -10...+60 °C
- Relative humidity: max. 95%, non-condensing
- If storage lasts longer than 3 months, regularly check the general condition of all parts and of the packaging.
- On SiloKings intended for export (overseas), bags with desiccant are placed into the inlets and outlets. These bags keep moisture away from the SiloKing's workspace. Remove bags before suction and pressure line are connected.

Installation and assembly

6 Installation and assembly

6.1 Safety

Electrical system



DANGER!
Mortal danger due to electric current!

There is mortal danger in case of contact with live components.

Activated electrically driven components can start to move uncontrolled and cause severest injuries.

Therefore:

- Switch off the electric power supply before commencing any work and secure against restarting.
- Work on the electrical system, on individual electrical components and on the connections may only be carried out by electrical specialists.

Dirt and lying about items



CAUTION!
Risk of tripping from dirt and objects lying around!

Contamination and discarded items can lead to slipping and tripping, resulting in substantial injuries.

Therefore:

- Always keep the working area clean.
- Remove objects that are not required.
- Mark tripping points with yellow-and-black tape.

As well observe all safety instructions in accordance with the operating instructions "SiloKing 700 / 1100 / 1500, SiloKing 700 / 1100 LS" chapter "Occupational safety".

6.2 Installation

The figure gives a schematic illustration of the SiloKing with accessories and drive variants.

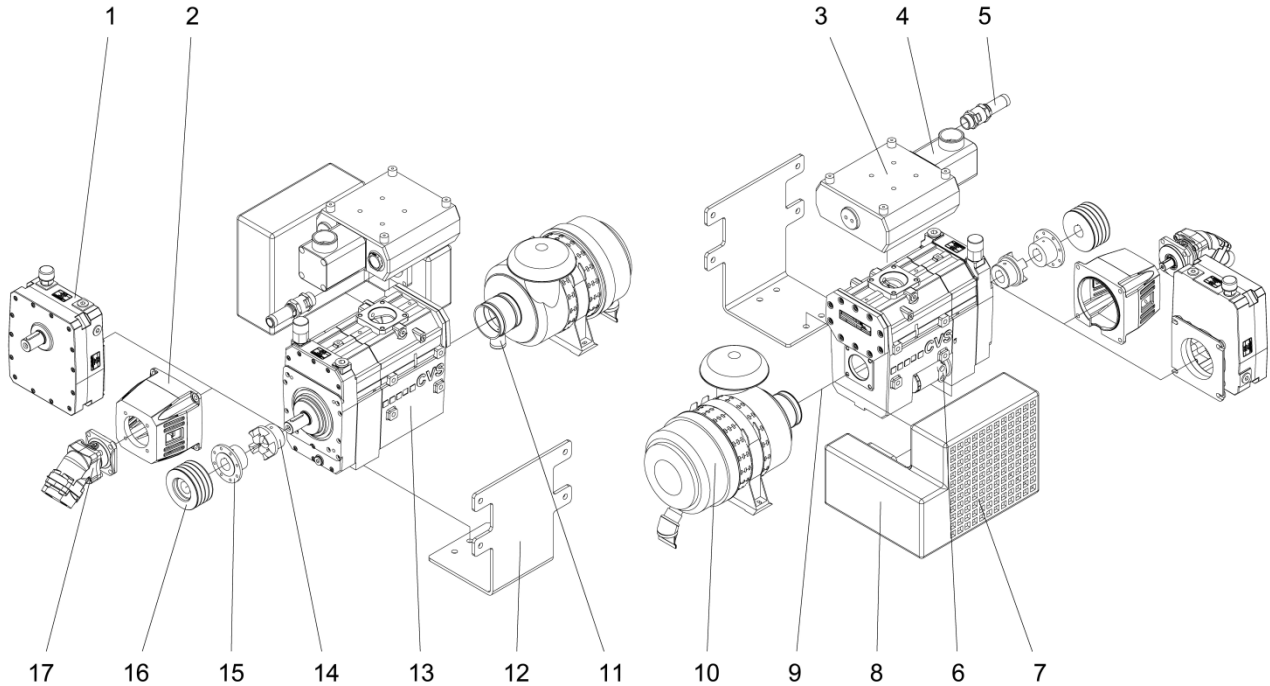

Fig. 5: SiloKing with accessories and drive variants

- | | | | | | |
|---|--|----|--|----|-----------------------------------|
| 1 | Adapter gear | 7 | Suction filter for direct installation | 13 | SiloKing |
| 2 | Intermediate flange for hydraulic motor installation | 8 | Suction silencer (muffler) | 14 | Flexible coupling |
| 3 | Pressure silencer (muffler) | 9 | Connection line (hose) | 15 | Articulated shaft mounting flange |
| 4 | Non-return valve | 10 | Suction filter for remote installation | 16 | V-belt pulley |
| 5 | Safety valve | 11 | Maintenance display | 17 | Hydraulic motor |
| 6 | Connection for external gearbox oil cooler | 12 | Installation panel | | |

6.3 Necessary work

The following work is necessary to install the SiloKing:

- Installing the SiloKing with suction and pressure lines.
- Installing safety and monitoring equipment.
- Installing accessories.
- Connect the drive to the SiloKing.

Installation and assembly

6.4 SiloKing screw compressor

The following installation methods are available for the SiloKing:

- via 4 attachment points on the bottom side of the SiloKing at the side of the vehicle on an installation panel or
- via 4 attachment points on the side of the SiloKing within the vehicle frame.

Requirements on the installation panel and the fixture

- The installation panel and attachment points on the vehicle must be of adequate load-carrying capacity and stiffness.
- The attachment points must be on the same level.
- The fastening screws must feature a sufficient clamping length.

Requirements upon the installation location

The installation location must fulfil the following requirements:

- Protect from dirt, falling rocks and spray water.
- Offer sufficient space for accidental contact protection.
- Offer sufficient space for the connections of the suction and pressure lines.
- Ensure good legibility of the instruments.
- be accessible for maintenance and repair work e.g. for replacing the oil filter, or for checking the safety and non-return valve.

Installation position

- The pressure flange must point upwards.
- Install the SiloKing horizontally or with tilt matching the inclination of the auxiliary drive.

Assembly

Install the SiloKing with screws according to the following table without tension.

Use the following screws when attaching the SiloKing:

Model	Screw	Model	Solidity	Torque	Screw depth in the housing of the SiloKing
700 / 1100 700 / 1100 LS	M16	Verbus Ripp	8.8	190 Nm	22...24 mm
1500	M20	Verbus Ripp	8.8	400 Nm	22...28 mm

Tab. 6: Fastening screws

6.5 Suction and pressure line

Requirements

The suction and pressure lines must meet the following requirements:

- corrosion-proof
- temperature resistant up to 250°C
- Minimum diameter:
 - Type 700 / 1100 Suction and pressure line DN 80
 - Type 1500: Suction line DN 150
Pressure line DN 100

Installation

The following points must be observed during installation:

- The lines must not have any reaction force on the SiloKing. Support the lines, if necessary.
- Lay the pressure line away from the SiloKing. Install a condensate sack with drain outlet at the lowest point.
- When using a plastic hose in connection with a remote suction filter ensure that the areas around the clamps are leak-proof.
- In the event of initial soiling on the suction side, a strainer must be temporarily mounted directly on the suction flange during start-up.
(Recommended mesh width: 0.1 mm).

6.6 Muffler (silencer)

There are high-frequency air fluctuations in screw compressor owing to their principle of operation.

We recommend installing a muffler on the suction and pressure side. Commercially available mufflers are fitted with a non-return valve and a connection for a safety valve.

Assembly

Install the muffler with screws according to the following table without tension.

Model	Screw	Solidity	Torque	Screw depth in the housing of the SiloKing
all models	M12	8.8	45 Nm	max. 19 mm

Installation and assembly

6.7 Safety equipment

The following safety equipment must be installed:

- Safety valve
- Non-return valve
- Suction filter
- Protection against contact

6.7.1 Safety valve

Risk of explosions



DANGER!

Risk of injury by explosions!

Explosions can cause severe injuries!

Therefore:

- Install the safety valve as instructed. Observe the manufacturer's instructions.
- Only use the safety valve for its intended purpose.
- Never block the safety valve.

The German accident prevention regulations require a non-lockable safety valve to be installed after the SiloKing at the pressure side. This valve must be selected such that it prevents the pressure to exceed the highest permissible operating pressure by more than 10 %. It must be identified with a TÜV component test number and be equipped with a manual venting element.

Assembly

1. Install the safety valve directly behind the SiloKing. There may not be any shut-off devices between the safety valve and the SiloKing.
2. The nominal opening pressure may not exceed the maximum permissible final overpressure (refer to chapter 3.2 Tab. 2) or the permissible system pressure, provided the latter is lower.

6.7.2 Non-return valve

The non-return valve prevents the reverse operation of the SiloKing after it has been switched off when the silo is not relieved. The non-return valve is not suitable for retaining material to be conveyed.

Assembly

- The non-return valve must be installed directly after the SiloKing or after the safety valve.
- A second non-return valve must be installed at the crossover to the consumer.

6.7.3 Suction filter

Liquids and solids may not be sucked in. Hence, a filter must be installed before the SiloKing.

Requirements

The filter must fulfil the following requirements:

- Filter: < 5 Micron
- Filter resistance when it is new: < 30 mbar
- It must be fitted with dust extraction valve, a control flap and a maintenance display for the degree of contamination.

Assembly

- Install the filter in the suction line before the SiloKing – either directly before the SiloKing with an intake silencer or away from the SiloKing via a connecting hose.
- Protect the filter from spray water, exhaust gases and heat.
- Observe the flow direction.
- Mount the filter horizontally.
- It must be possible to dismantle the filter cartridge for maintenance.

6.7.4 Protection against contact

Moving and hot parts must be protected against contact.

The protective measures for moving parts, e.g. to DIN EN ISO 13857, for hot surfaces, e.g. to DIN EN ISO 13732-1, must be implemented.

Installation and assembly

6.8 Display and monitoring equipment

Pressure gauge, maintenance display and thermometer must be provided to ensure smooth and trouble-free operation.

We also recommend the installation of a speed counter.

Designation	Monitoring parameters	Place of installation	Measuring range
Pressure gauge	Operating pressure	at the SiloKing, see chapter 4.1 Fig. 4	according to the operating pressure to be ensured
Pressure gauge	Gearbox oil pressure	at the SiloKing, see chapter 4.1 Fig. 4	0...16 bars
Maintenance display	Degree of contamination of the suction filter	Suction filter	0...65 mbars
Thermometer	Compression end temperature	at the SiloKing, see chapter 4.1 Fig. 4	0...250 °C
Speed counter (option)	Speed	Drive shaft	refer to chapter Tab. 3.

Tab. 7: Display and monitoring equipment

6.9 Oil cooler

In case of continuous operation beyond 3 hours or with extremely encapsulated installation, an oil cooler must be installed. The connection lines are fitted via an adapter, which is installed instead of the oil filter.

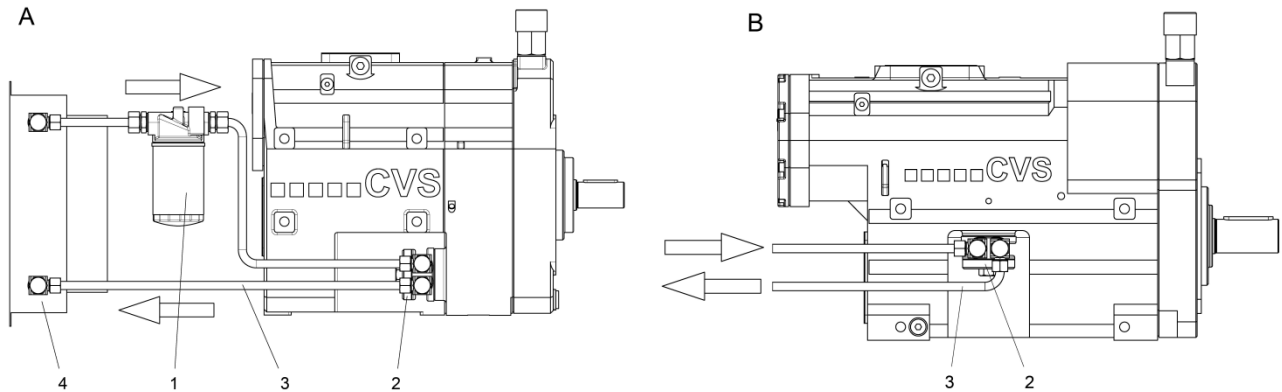

A: SiloKing 700 / 1100 / 700 LS / 1100 LS

B: SiloKing 1500

NOTE: Suitable oil coolers are available from CVS.

Fig. 6: Oil cooler

- 1 Oil filter in the return flow
- 2 Adapter for external oil circulation
- 3 Line to the oil cooler
- 4 Oil cooler with ventilator

6.10 Compressed air after-cooler

Depending on the material being transported or the material of the pressure line, a compressed air aftercooler with a cooling air blower must be installed.

Installation and assembly

6.11 Drive



ATTENTION!

- The drive components must not exert any axial forces on the drive shaft.
- When doing any assembly work on the drive shaft, no forces must be exerted on the drive shaft.
- Do not hammer or knock connecting components on the shaft, but pull them instead.
- Check the torque and the sense of rotation.

Drive types

The SiloKing can be driven by means of:

- V-belt via the auxiliary drive of the heavy goods vehicle, diesel engine or electric motor
- Articulated shaft by the auxiliary drive of the heavy goods vehicle (PTO)
- Flexible coupling and intermediate flange by a hydraulic motor
- Flexible coupling and adapter gear

6.11.1 V belt drive



ATTENTION!

Do not exceed the maximum permissible lateral force at the shaft of the SiloKing:

- max. 4500 N type 700 / 1100 / 700 LS / 1100 LS
- max. 9000 N type 1500
- for SiloKing with adapter gear: see 6.11.4

Observe the design, installation and inspection instructions of the manufacturer.

The following belt pulleys can directly be installed on the shaft end of the SiloKing:

Design data of the V-belt drive	Unit	Model 700		Model 1100			Model 1500			
		SPA	XPA	SPA	XPA	SPB	XPB			
Belt profile	–	SPA	XPA	SPA	XPA	SPB	XPB			
Smallest pulley diameter	[mm]	125	140	125	180	160	180	224	190	200
Number of belts	–	5	4	4	5	4	4	6	6	5

Design data of the V-belt drive	Unit	Model 700 LS		Model 1100 LS	
		SPA	XPA	SPA	XPA
Belt profile	–	SPA	XPA	SPA	XPA

Design data of the V-belt drive	Unit	Model 700 LS			Model 1100 LS	
Smallest pulley diameter	[mm]	140	125	140	180	180
Number of belts	–	5	5	4	5	4

Install V-belt pulley

Install the V-belt pulley and V-belt as specified by the manufacturer.

Install the V-belt

1. Align the shaft axes and V-belt grooves of the motor and the SiloKing in parallel.
2. Install the V-belt with the pre-tension specified by the manufacturer.
3. Pull up the V-belt pulley right up to the stop on the drive shaft.

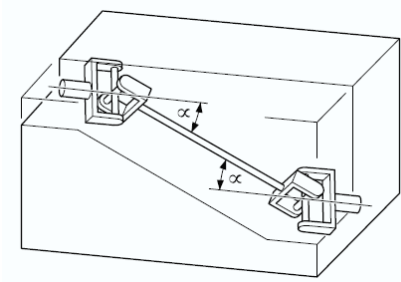
6.11.2 Articulated shaft drive

ATTENTION!

Do not exceed the maximum permissible lateral force at the shaft of the SiloKing:

- max. 4500 N type 700 / 1100 / 700 LS / 1100 LS
- max. 9000 N type 1500
- for SiloKing with adapter gear: see 6.11.4

Observe the design, installation and inspection instructions of the manufacturer.

Select the bending angle of the joint shaft α at max. 15°.

The central axes of the joint shaft must run parallel to each other.

Assembly

Install the articulated shaft as specified by the manufacturer.

6.11.3 Drive via flexible coupling and hydraulic motor
Design and assembly

Lay and install the flexible coupling and hydraulic motor as specified by the manufacturer.

ATTENTION!

Observe the design, installation and inspection instructions of the manufacturer.

Installation and assembly

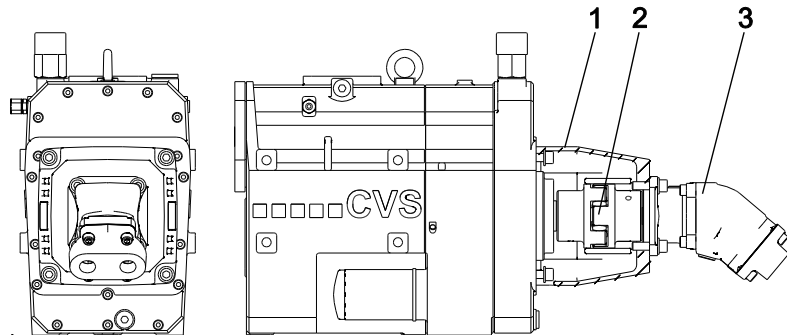

Fig. 7: Drive via flexible coupling and hydraulic motor

- 1 Intermediate flange
- 2 Flexible coupling
- 3 Hydraulic motor

You can purchase the intermediate flange, flexible coupling and hydraulic motor via CVS.

6.11.4 Drive via adapter gear (SiloKing 700 / 1100 / 700 LS / 1100 LS)



ATTENTION!

The maximum permissible lateral force on the shaft of the SiloKing must not exceed 1000 N.

There are three items for gearbox drive shafts available for various installation conditions. SiloKing gear and adapter gear are each provided with their own oil circulation. The drive may only take place via a flexible coupling or via an articulated shaft. Using a V-belt drive is ruled out. The adapter gear is installed on the SiloKing at the factory. Two slow ratios are available, $i=2.0$ and $i=2.5$. The new drive speed results from dividing the SiloKing drive speed (see chapter 3.2 Tab. 3) by the ratio i .

SiloKing with adapter gear can be designed for clockwise or counterclockwise rotation. Observe the rating plate and the direction of rotation arrow on the gear.

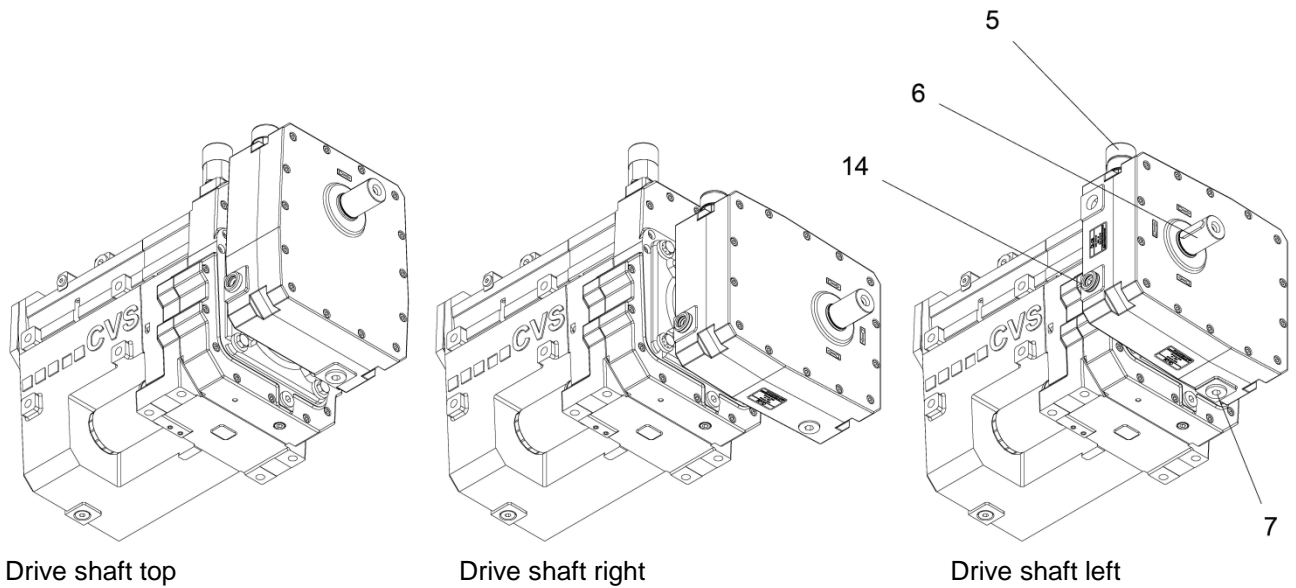

Fig. 8: Attachment variants for adapter gears, for example on type LS

- 5 Oil filler neck cap / gear ventilation
- 6 Drive shaft with feather key
- 7 Oil drain screw
- 14 Oil sight glass

Gear oil specification

See chapter 3.2 Tab. 4 and Tab. 5

Changing the gear oil on the adapter gear

Open oil filler cap (Fig. 8, pos. 5) and oil drain plug (Fig. 8, pos. 7), drain oil. Close oil drain plugs (Fig. 8, pos. 7) and fill with fresh oil to the top edge of the oil sight glass (Fig. 8, pos. 14). Fit oil filler cap (Fig. 8, pos. 5).

You can purchase the adapter gear from CVS.
Other data on request.

Start-up

7 Start-up

7.1 Safety during start-up

Start-up, operation



WARNING!

Risk of injury due to improper start-up and operation

Improper start-up and operation can lead to serious bodily injuries or property damage.

Therefore:

- Have all work during initial operation exclusively performed by the manufacturer's employees or by his authorised representatives or by trained personnel.
- Start-up and operation may only be performed by adequately qualified personnel that has been authorised and instructed by the operator.
- Before the start of any work, ensure that all covers and protective devices are correctly installed and function correctly.
- Never override any protective equipment during operation.
- Pay attention to tidiness and cleanliness in the working area! Loosely stacked or scattered components and tools are accident sources.

As well observe all safety instructions in accordance with the operating instructions "SiloKing 700 / 1100, SiloKing 700 / 1100 LS, SiloKing 1500" chapter "Occupational safety".

7.2 Start-up



ATTENTION!

The SiloKing must always be supplied with sufficient oil. Check oil level with screwed-in oil dip stick and top up with oil if necessary. See rating plate oil on the SiloKing or chapter 3.2 Tab. 4

Inspection prior to initial start-up

The following points must be checked prior to initial start-up:

- Transport damage to the SiloKing
- Checking the entire system
- Conduits for free passage and leak tightness. Remove dirt, welding residues and rust, if necessary.
- Screw connections for tightness
- Direction of rotation of the drive by switching it on and off briefly (correct direction of rotation: clockwise as seen on the drive shaft (for SiloKing without adapter gear), see direction of rotation arrow)
- Oil level
- Direction of installation and function of non-return valve
- Safety valve function
- Accidental contact protection function.

Start-up

- Ensure that the SiloKing is positioned at an acceptable angle (see chapter 3.2 Tab. 1)
- Depressurise the pressure side
- Open shut-off devices
- Switch on drive (engage gently)
- Adjust input speed
- Check operating data

Inspections during operation

During operation **the operator** has to check the following data **every 20 minutes**:

- Drive speed (see chapter 3.2 Tab. 2)
- Final overpressure (see chapter 3.2 Tab. 2)
- Gear oil pressure (see chapter 3.2 Tab. 3)

7.3 Switching off

Switch off the SiloKing as follows:

- Switch off drive.
- Close shut-off valves.
- Drain condensate if necessary, e.g. when using a compressed air aftercooler.

EC Declaration of Incorporation

8 EC Declaration of Incorporation

Declaration of Incorporation according to the EC Machinery Directive 2006/42/EC, Annex II 1B

Translation of the original Declaration of Incorporation

<i>Manufacturer:</i>	CVS engineering GmbH Großmattstraße 14 D-79618 Rheinfelden
<i>Authorised person for compilation of the relevant technical documents:</i>	Manfred Wagner Großmattstraße 14 D-79618 Rheinfelden
<i>Product:</i>	Screw compressor SKL 700 / SKL1100 / SKL 700 LS / SKL 1100 LS / SKL 1500

The manufacturer declares that the above product is an incomplete machine in the meaning of the machinery directive. The product is only intended for installation in a machine or an incomplete machine and therefore does not meet all requirements of the machinery directive yet.

The following basic requirements of the machinery directive for this product have been applied and complied with: 1.1.2, 1.1.3, 1.1.5, 1.3.1, 1.3.2, 1.3.4, 1.3.7, 1.5.5, 1.5.7, 1.5.8, 1.5.9, 1.6.1, 1.7.1, 1.7.2, 1.7.3, 1.7.4

The special technical documents have been created according to Annex VII, part B. The person authorised to compile the technical documents commits to submitting the documents to the national offices upon justified request. The submission shall take place on paper in the email or on electronic data carrier.

Commissioning of the product is forbidden until it has been determined that the machine into which the above product is installed meets all basic requirements of the machinery directive.

Rheinfelden, 28.03.2018

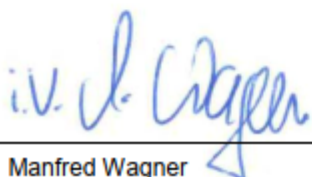

Manfred Wagner
Head of Development and Design

Index

A

Acceptance	8
Articulated shaft drive	29

C

Compressed air after-cooler	27
Contact person	7
Copyright protection	7
Customer Service	7

D

Danger pictograms	9
Dangers	9
Dimensions	10
Dirt	20
Display equipment	26
Drive	28
Drive via adapter gear	30

E

EC Declaration of Incorporation	7, 34
Electrical specialist	8

G

Gear oils, recommended	15
------------------------------	----

H

Hydraulic motor drive	29
-----------------------------	----

I

Inspection	
during operation	33
prior to initial start-up	33
Installation and assembly	20
Installing SiloKing	22
Intended use	8

L

Liability	7
-----------------	---

M

Monitoring equipment	26
Muffler (silencer)	23

N

Non-return valve	25
------------------------	----

O

Occupational safety	9
Oil cooler	27
Operating instructions	5
Operator	8

P

Pressure line	23
Protection against contact	25
Protective equipment	9

S

Safety	8
Safety equipment	24
Safety valve	24
Spare parts	7
Specialised staff	8
Staff	8
Start-up	32
Storage	18, 19
Suction filter	25
Suction line	23
Switching off	33
Symbols in the instructions	6

T

Technical data	10, 13
Transport	18

V

V belt drive	28
--------------------	----

W

Warranty	7
----------------	---

