

Operating instructions

Multi-cell compressor
RKL 160



Doc-ID: 5007 / BA / EN

Release: Rev. 03 / 07/02/2018

The operating instructions must be read by the RKL 160 operator before start-up!

Translation of the original operating manual

© CVS engineering GmbH

Großmattstraße 14
79618 Rheinfeldern / Germany

Phone: +49 (0)7623 71741-0
Customer service: +49 (0)7623 71741-0
E-Mail: info@cvs-eng.de
Internet: www.cvs-eng.de



Contents

Contents	3
1 General	5
1.1 Information regarding the operating instructions	5
1.2 Pictogram explanation	6
1.3 Limitation of Liability	7
1.4 Copyright protection	7
1.5 Spare parts	8
1.6 Warranty conditions	8
1.7 Customer Service	8
2 Safety	9
2.1 Intended use	9
2.2 Acceptance and monitoring	9
2.3 Operator's responsibility	9
2.4 Operating personnel	10
2.4.1 Requirements.....	10
2.5 Personal protective equipment	10
2.6 Occupational safety and special risks	11
3 Technical data	16
4 Design and function.....	17
4.1 Design.....	17
4.2 Cooling.....	18
4.3 Function	18
4.4 Control and display elements	19
5 Transport and storage	20
5.1 Safety notes for transport	20
5.2 Transport.....	20
5.3 Storage	20
6 Start-up and operation	21
6.1 Safety notes	21
6.2 Start-up	21
6.3 Switching off.....	21
6.4 Inspections to be performed	21
7 Maintenance	23
7.1 Safety during maintenance work	23
7.2 Maintenance schedule	23
7.3 Performance of maintenance work	24

Contents

8	Malfunctions	25
8.1	Safety	25
8.2	Recommissioning after corrective action	25
8.3	Malfunction table	26
9	Spare parts.....	27
10	Decommissioning and disposal	27
	Index.....	28

1 General

1.1 Information regarding the operating instructions

These operating instructions provide important information on how to deal with the multi-cell compressor RKL 160 (hereinafter referred to as "RKL 160"). A precondition for safe operation is the observance of all specified safety and handling instructions.

Furthermore, all local accident prevention regulations and general safety regulations valid for the application area of the RKL 160 must be observed.

Carefully read the operating instructions before starting any work! It is a product component and must be kept in direct proximity of the RKL 160, well accessible to the personnel at all times.

When passing the RKL 160 on to third parties, the operating instructions must also be handed over.

General

1.2 Pictogram explanation

Warning notes

Warning notes are characterised by pictograms in these operating instructions. The warning notes are marked by signal words expressing the extent of the hazard.

It is absolutely essential to observe the notes and to proceed with caution in order to prevent accidents as well as bodily injuries and property damage.



DANGER!

... points to an immediately dangerous situation, which can lead to death or serious injuries if it is not avoided.



WARNING!

... points to an immediately dangerous situation, which can lead to death or serious injuries if it is not avoided.



CAUTION!

... points to a potentially dangerous situation, which can lead to minor or light injuries if it is not avoided.



ATTENTION!

... points to a potentially dangerous situation, which may lead to property damage if it is not avoided.

Hints and recommendations



NOTE!

... highlights useful hints and recommendations as well as information for an efficient and trouble-free operation.

1.3 Limitation of Liability

All specifications and notes in these operating instructions were compiled with consideration to the valid standards and regulations, the state of the art as well as to our long-standing knowledge and experience.

The manufacturer is not liable for damages caused by:

- Non-observance of the operating instructions
- Improper use
- Deployment of non-trained personnel
- Arbitrary modifications
- Technical changes
- Use of non-approved spare and wear parts.

The actual scope of supply may differ from the explanations and illustrations described in this manual in case of special designs, if additional order options are made use of, or due to latest technical changes.

Incidentally, the responsibilities agreed upon in the delivery contract, the general terms and conditions as well as the manufacturer's conditions of delivery and the statutory provisions valid at the time of contract conclusion shall apply.

Warranty

The manufacturer guarantees the correct functioning of the applied process technology and the performance parameters identified.

The warranty period commences on the date the RKL 160 is delivered to the customer.

Components are exempted from the warranty and from claims for defects as far as wear and tear damage is concerned.

1.4 Copyright protection



NOTE!

Content details, texts, drawings, pictures and other illustrations are protected by copyright and are subject to industrial property rights. Any improper use shall be liable to prosecution.

Any type and form of duplication also of extracts as well as the exploitation and/or communication of the contents are not permitted without the manufacturer's written declaration of consent.

General

1.5 Spare parts



WARNING!

Risk of injury by incorrect spare parts!

Incorrect or defective spare parts can result in damage, malfunctions or total failure and also impair safety.

Therefore:

- Use only the manufacturer's original spare parts.

Procure spare parts from authorised dealers or directly from the manufacturer. Refer to page 2 for address.

1.6 Warranty conditions

Warranty terms see "General Terms of Sale".

1.7 Customer Service

Our customer service can be contacted for any technical advice. Information about the responsible contact person can be retrieved by telephone, fax, E-mail or via the Internet at any time, refer to manufacturer's address on page 2.

2 Safety

2.1 Intended use

The multi-cell compressor RKL 160 is intended exclusively for the compression of filtered air. The RKL 160 has been developed for installation into a superordinate system.

Only use the RKL 160 for the intended use.

All specifications in the operating instructions must be strictly adhered to (technical data, operating data, permissible working range), refer to Page 16, chapter 3 in this regard.

All types of claims due to damage arising from improper use are excluded. The operator alone shall be responsible for any damage arising from improper use.

2.2 Acceptance and monitoring

The RKL 160 is not subject to any acceptance and monitoring obligation.

2.3 Operator's responsibility

The RKL 160 is used for industrial purposes.

The operator of the RKL 160 is therefore subject to the legal obligations concerning occupational safety.

The provisions valid at the place of installation as well as the safety and accident prevention regulations of the Institution for statutory accident insurance and prevention must be observed. The operator must in particular:

- inform himself on the valid industrial safety regulations.
- determine the additional hazards that arise from the special working conditions at the RKL 160's place of installation by means of a hazard assessment.
- implement the necessary rules of conduct for operation of the RKL 160 at the place of installation by means of user instructions.
- check at regular intervals during the RKL 160's entire period of use whether the user instructions correspond to the current state of the body of rules and regulations.
- adapt the operation instructions, if necessary to the new regulations, standards, and operating conditions .
- clearly regulate the responsibilities for installing, operating, maintaining and cleaning the RKL 160.
- ensure that all employees working on or with the RKL 160 have read and understood the operating instructions. In addition he must at regular intervals train the employees in how to deal with the RKL 160 and inform them about potential hazards.

Safety

In addition, it is the operator's responsibility to ensure that RKL 160:

- the machine is always in a technically perfect condition.
- the machine is maintained in accordance with specified maintenance intervals.
- all safety equipment is regularly checked for completeness and correct functioning.

2.4 Operating personnel

2.4.1 Requirements



WARNING!

Risk of injury in case of inadequate qualification!

Improper handling can lead to considerable bodily injuries and property damage.

Therefore:

- Have any activities only carried out by the individuals designated for that purpose.

The operating instructions specify the following qualification requirements for the different fields of activity:

- **Instructed persons**
have been instructed during instructions provided by the operator with regard to the work assigned to them and possible hazards arising from improper conduct.
- **Specialists**
are due to their technical training, knowledge and experience and their knowledge of the pertinent regulations able to carry out the work assigned to them and to independently recognize potential hazards.

2.5 Personal protective equipment

When handling the RKL 160, it is necessary to wear personal protective equipment, in order to minimise health hazards.

- Before carrying out any work, properly don the necessary protective equipment such as gloves, safety goggles, etc. and wear during work.

2.6 Occupational safety and special risks

The remaining risks that result from the hazard analysis are specified in the following section.

Observe the safety notes listed here and the warning notes in the other chapters of these instructions to reduce health hazards and to avoid dangerous situations.

Danger symbols at the RKL 160

The relevant dangerous spots on the RKL 160 are identified by these pictograms:



DANGER!
General danger pictogram!

... denotes general dangerous situations for individuals. Non-observance of the safety instructions can result in severe injuries or death.



DANGER!
Danger of burns!

... denotes the presence of a hot surface.

Safety

Hazard notes and occupational safety

For your own safety and that of the machine, the following information must be observed and complied with:

Improper operation



DANGER!

Danger due to improper operation!

- Only use RKL 160 in a perfect technical condition. Malfunctions that are relevant for safety have to be promptly eliminated.
- Conversions of the RKL 160 are not permissible and can impair safety.
- Never bridge any safety equipment or put it out of operation.
- Any work on the RKL 160 and/or on electrical equipment must be carried out by specialised staff.
- Repair and maintenance work may only be carried out when the RKL 160 is stationary. For this, the RKL 160 must be secured against restarting!
- The RKL 160 may not be under pressure or in a state of vacuum while work is being carried out on it.
Close shut-off valve on the vehicle side and vent the pipe between RKL 160 and shut-off valve or manually relieve excess pressure at safety valve. Observe pressure gauge!
- The drive's protective equipment may only be removed when the RKL 160 is stationary and has to be correctly refitted after completion of work.
- Only dismantle accidental contact protection after RKL 160 and pipe has cooled down.
- It is an environmental protection requirement that any liquids arising during maintenance work (e.g. oil) must be collected and disposed of in an environmentally compatible manner.

Moving components

WARNING!
Risk of injury by moving components!

Powered rotating components can cause the most serious injuries!

Therefore during operation:

- It is absolutely forbidden for persons to stay in the hazard area or in the immediate vicinity!
- Do not put safety devices and/or functions out of operation and do not render them inoperative or bypass them.
- Never reach into open outlets and inlets or into running equipment.

Before entering the hazard area:

- Switch off power supply and secure against restarting.
- Wait for standstill of lagging components.
- Wait for automatic dissipation and/or discharge of residual energies (compressed air).

Compressed air

WARNING!
Risk of injury due to compressed air!

Pneumatic energies can cause the most serious injuries.

In the case of damage to individual components, air can be discharged under high pressure and injure e.g. the eyes. Therefore:

- Before starting any work, first depressurise pressurised components. Pay attention to accumulators. Accumulator pressure must also be completely relieved.

Signposting

WARNING!
Risk of injury by illegible pictograms!

Labels and signs can become dirty or unrecognisable in the course of time.

Therefore:

- Always keep safety, warning and operating instructions in a well legible condition.
- Immediately replace damaged or obliterated signs or labels.

Safety

Improper transport



Danger! **Danger by falling down or tilting of the RKL 160!**

The weight of the RKL 160 may injure a person and cause serious bruising!

Therefore:

- Depending on the dead weight and size of the RKL 160, use a pallet on which the RKL 160 can be moved by means of a fork lift.
- For lifting the RKL 160, use suitable lifting gear (slings, etc.) that is designed for the weight of the RKL 160.
- When putting the slings in position, take care to avoid putting stress on individual components.
- Only use the provided attachment points with eye bolts.

Start-up, operation



WARNING! **Risk of injury due to improper start-up and operation**

Improper start-up and operation can lead to serious bodily injuries or property damage. Therefore:

- Have all work during initial operation exclusively performed by the manufacturer's employees or by his authorised representatives or by trained personnel.
- Start-up and operation may only be performed by adequately qualified personnel that has been authorised and instructed by the operator.
- Before the start of any work, ensure that all covers and protective devices are correctly installed and function correctly.
- Never override any protective equipment during operation.
- Pay attention to tidiness and cleanliness in the working area! Loosely stacked or scattered components and tools are accident sources.

Electrical system

DANGER!
Mortal danger due to electric current!

There is mortal danger in case of contact with live components.

Activated electrically driven components can start to move uncontrolled and cause severest injuries.

Therefore:

- Switch off the electric power supply before commencing any work and secure against restarting.
- Work on the electrical system, on individual electrical components and on the connections may only be carried out by electrical specialists.

Maintenance and troubleshooting

WARNING!
Risk of injury due to improper maintenance and troubleshooting!

Improper maintenance and troubleshooting can lead to serious bodily injuries or property damage.

Therefore:

- Maintenance work and troubleshooting work may only be carried out by sufficiently qualified and instructed personnel.
- Secure RKL 160 against restarting, switch off drives!
- Before starting any work, provide for sufficient space and freedom of movement during assembly.
- Pay attention to tidiness and cleanliness in the assembly area! Loosely stacked or scattered components and tools are accident sources.

If components must be replaced:

- Pay attention to correct installation of spare parts.
- Properly reassemble all fastening elements.
- Observe screw tightening torques.
- Before restarting, ensure that all covers and protective devices are correctly installed and function correctly.
- After completion of maintenance work and troubleshooting, check correct functioning of safety equipment.

Technical data

3 Technical data

General data	Unit	RKL 160
Weight RKL 160	[kg]	33
Rated speed	[1/min]	1500
Sound pressure level at final overpressure = 2.0 bar ¹⁾	[dB(A)]	75

1) Distance to RKL 160 = 7 m

Tab. 1: General data

Permissible working range	Unit	RKL 160
Speed range	[1/min]	1200...1600
Suction temperature ¹⁾	[°C]	-10...+40
Geodetic height ¹⁾	[m]	0...1000
Vacuum suction side	[mbar]	0...65
Maximum final overpressure at the pressure flange ²⁾	[bar]	2.5

1) Consult CVS for suction temperature and/or altitudes outside the permissible working range.

2) Intake pressure at the suction flange = 1 bar, suction and ambient temperature = 20 °C

Tab. 2: Permissible working range

Performance characteristics at 1500 1/min	Unit	RKL 160
Suction volume flow at final overpressure	0.0 bar	145
	2.0 bar	115
Coupling output at final overpressure	0.0 bar	4.5
	2.0 bar	8.1

1) Intake pressure at the suction flange = 1 bar, suction and ambient temperature = 20 °C

Tab. 3: Performance characteristics at rated speed

4 Design and function

4.1 Design

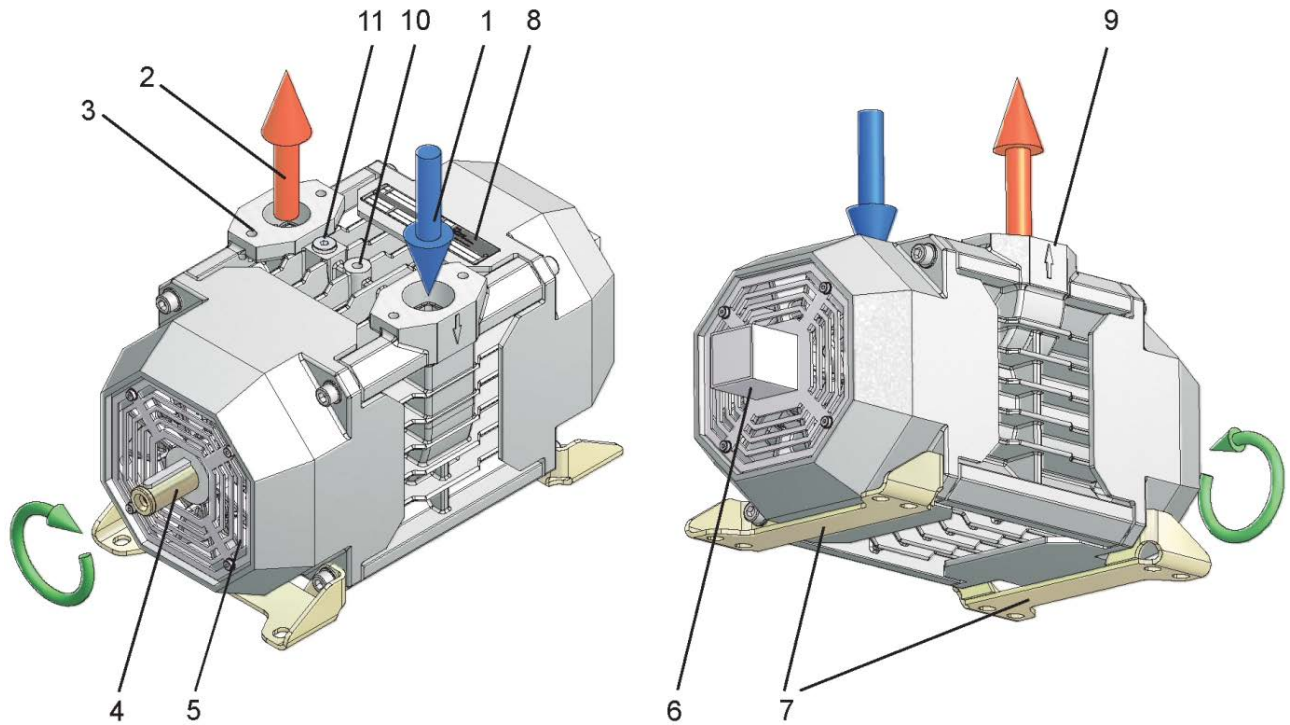

Fig. 1: Design

- | | | | |
|---|----------------------------------|----|--|
| 1 | Suction flange – air entry DN 40 | 6 | Shaft protection grid counter-side |
| 2 | Pressure flange – air exit DN 32 | 7 | Fixing feet |
| 3 | Attachment thread for flanges | 8 | Rating plate |
| 4 | Drive shaft | 9 | Rotation arrow |
| 5 | Shaft protection grid drive side | 10 | Thread for eye bolt M10 |
| | | 11 | Connection for pressure or temperature monitoring G ¼" |

Design and function

4.2 Cooling

The RKL 160 is air-cooled. Ensure at installation that no heat accumulation results and that the cooling air can circulate freely. The front cooling air entry openings must not be covered.

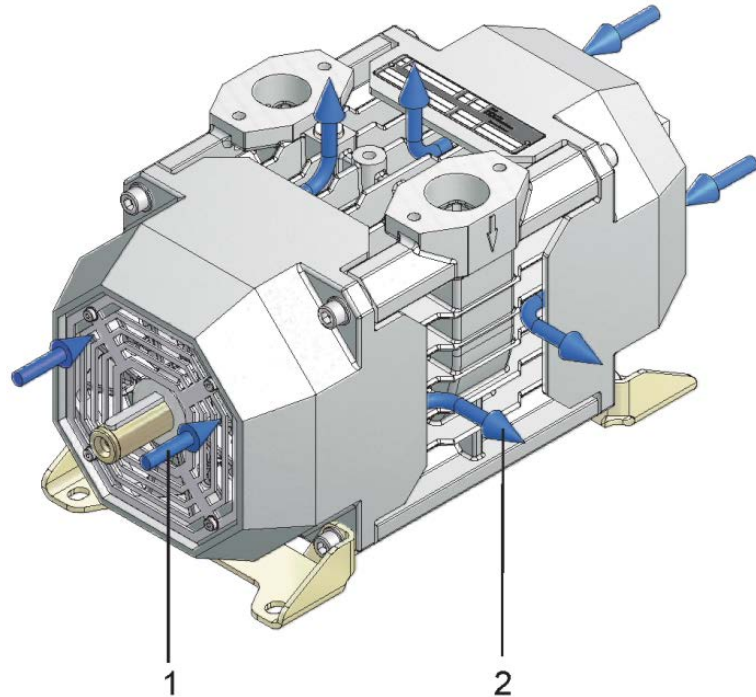

Fig. 2: Cooling air guide

- 1 Cooling air entry
- 2 Cooling air exit

4.3 Function

Functional principle

In the working area, self-lubricating sliders in conjunction with the impeller and the casing form cells that are separated from each other and steadily grow (sucking) or shrink (compressing) with each revolution.

Lubrication

Lubrication of the rotor bearing is warranted by a permanent grease fill.

Cooling

Heat removal is performed by casing ribs on the entire casing surface with targeted cooling air guidance, via a ventilation wheels.

Drives

The RKL 160 can be driven via:

- Articulated shaft
- V-belt
- Flexible coupling

Details about the drives and their design can be found in the separate mounting instructions for the RKL 160.

4.4 Control and display elements

Depending on the installation situation, different display elements such as pressure gauge, temperature gauge and negative pressure display are mounted.

Transport and storage

5 Transport and storage

5.1 Safety notes for transport

See chapter 2.6 "Occupational safety and special risks".

5.2 Transport

The RKL 160 fastened on a baseplate must be transported by means of a fork lift or suitable straps. The lifting gear must be designed for the weight of the RKL 160.

For future transports:

- Seal all open connections with protective caps (prevents penetration of dirt and water)
- Secure against vibrations
- Securely fasten the RKL 160 prior to transport (e.g. screw it onto a pallet)
- Transport and put down the RKL 160 with a fork lift or secure with straps and lift with suitable lifting gear.

5.3 Storage

Storage of packages

Store packages under the following conditions:

- Do not store outdoors.
- Store dry and dust free.
- Do not expose to aggressive media.
- Protect against solar irradiation.
- Avoid mechanical vibrations.
- Storage temperature: -10 to +60 °C
- Relative humidity: max. 95%, non-condensing
- If storage lasts longer than 3 months, regularly check the general condition of all parts and of the packaging.

6 Start-up and operation

6.1 Safety notes

See chapter 2.6 "Occupational safety and special risks".

6.2 Start-up

Inspection prior to initial start-up

The following points must be checked prior to initial start-up:

- Transport damage at the RKL 160
- Conduits for free passage and leak tightness.
- Screw connections for tightness.
- Drive's sense of rotation by briefly switching it on and off (observe rotation direction arrow).
- Direction of installation and function of non-return valve.
- Safety valve function.
- Accidental contact protection function.

Start-up

- Open present shut-off devices
- Switch on drive (engage gently)
- Adjust input speed
- Check the operating data.

Inspections during operation

During operation **the operator** has to check the following data **every 10 minutes**:

- Input speed (see Tab. 2)
- Final overpressure (see Tab. 2).

6.3 Switching off

Switch off the RKL 160 as follows:

- Switch off drive.
- Close the shut-off valves (if installed)
- Drain the condensate tank (if available) Tank may not be under pressure then.

6.4 Inspections to be performed

Non-return valve inspection

The non-return valve is maintenance free, but is subject to wear like any other moving part. We recommend a visual inspection every 3 months. In this connection, the non-return valve must be dismantled, cleaned, freed of deposits and checked for freedom of motion.

Start-up and operation

Safety valve inspection

The safety valve is no regulating device!

The operational capability must be checked on start-up and later at weekly intervals.

The safety valve must be secured against misadjustment. Blocking or manipulating the safety valve can have penal consequences if it gives rise to an accident. Any warranty claims shall also be forfeited in such a case.

The nominal opening pressure may not exceed the maximum permissible final overpressure (refer to Tab. 2) or the permissible system pressure, provided the latter is lower.

Functional testing is carried out by actuating the manual ventilation with the RKL 160 running.

Height wear rotor vanes

Based on a daily runtime of 3 to 4 hours, the initial inspection should be performed after approx. 6 months. For further inspections, see page 23, Tab. 4 "Maintenance schedule".

Measuring height wear

1. Remove pressure flange.
2. Check vane recess with sliding calliper. The rotor vanes must be replaced if the sliders show a recess of more than 7 mm as compared to the rotor jacket.
3. Install pressure flange

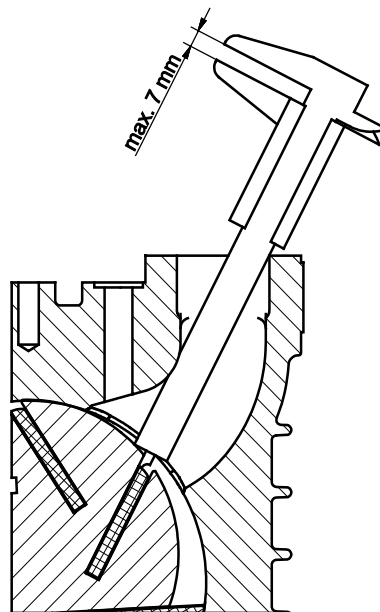

Fig. 3: Measuring the height wear rotor vanes

7 Maintenance

7.1 Safety during maintenance work

See chapter 2.6 "Occupational safety and special risks".

Personal protective equipment

The following must be worn during all maintenance work:

- Safety working clothing
- Protective gloves
- Safety shoes
- Safety goggles

7.2 Maintenance schedule

The following describes the maintenance work that is necessary for an optimum, trouble-free operation. Maintenance intervals must be observed.

If increased wear of individual components or functional groups is determined during regular inspections, the operator has to reduce the required maintenance intervals on the basis of the actual signs of wear.

Changes compared to normal operation (increased power consumption, temperatures, vibrations, noises, etc. or response of monitoring systems) lead to the assumption that the functions are impaired. These then have to be subjected to an inspection by specialised staff.

In case of queries regarding the maintenance work and intervals: contact the manufacturer (service address → page 2).

For maintenance schedule refer to next page.

Maintenance schedule

Interval	Maintenance work	To be carried out by
Weekly	Check the retaining screws ¹⁾ (see Chapter 6.4).	Operator
	Clean RKL 160 (see chap. 7.3).	
	Check and clean cooling air guidance (refer to chapter 7.3).	
	Check air filter's degree of soiling (refer to chapter 7.3)	
	Check air filter hose for leaks.	
	Check connection to drive (articulated shaft, coupling) ¹⁾ .	
quarterly	Check screw connections.	Specialised staff
	Check height wear of pipe slider (refer to chapter 6.4).	
	Check non-return valve (refer to chapter 6.4).	

1) Observe manufacturer's recommendations

Tab. 4: Maintenance schedule

Maintenance

7.3 Performance of maintenance work

Cleaning of the RKL 160

Observe the following when cleaning the RKL 160:

1. Switch off RKL 160 and secure against restarting.
2. Remove soiling appropriately. Observe the following:
 - Do not use aggressive cleaning agents.
 - Pay attention during cleaning that no water gets into the compression chamber.
 - Exercise special caution when cleaning with high-pressure cleaning systems.
 - After cleaning work, check that all previously opened covers and safety equipment are correctly installed and function correctly.
 - After wet cleaning, warm up the RKL 160 for a few minutes.

Cooling of the RKL 160

To warrant best cooling, the protective grid apertures must be free of deposits.

Suction air filter

The contamination state is usually indicated by a maintenance display. If maintenance is required, open filter casing and replace filter cartridge.

Action after lengthy standstill

If the standstill of the RKL 160 installed inside the vehicle lasts for more than a month, we recommend putting the RKL 160 into operation once a month for 15 minutes.

8 Malfunctions

This chapter describes possible causes of malfunctions and troubleshooting tasks.

Reduce the maintenance intervals if similar malfunctions occur repeatedly due to above-average intensive use so intervals correspond to the actual load.

Contact the manufacturer in case of malfunctions that cannot be repaired with the aid of the following information (→ p. 2)!

8.1 Safety

See chapter 2.6 "Occupational safety and special risks".

Personnel

- The trouble shooting work described at this point can be carried out by the operator, unless otherwise indicated.
- Some work may only be carried out by specially trained specialised staff or exclusively by the manufacturer himself. This is specifically pointed out in the description of the individual malfunctions.
- Only electrical specialists may carry out work on the electrical system.
- Components and parts may only be replaced by specialised staff.

Personal protective equipment

See chapter 2.5.

Conduct in the case of malfunctions

The following basically applies:

1. Immediately switch off the RKL 160 in case of malfunctions representing an immediate danger for individuals or material assets.
2. Switch of all power supplies and secure against restarting.
3. Inform person in charge at the place of installation.
4. Depending on the type of malfunction, have the cause determined and eliminated by responsible and authorised specialised personnel.

8.2 Recommissioning after corrective action

After corrective action or trouble shooting:

1. Reset emergency stops.
2. Acknowledge error message or malfunction at the control system.
3. Ensure that nobody is staying in the hazard area.
4. Start in accordance with the instructions in chapter „start-up“.

Malfuncions

8.3 Malfunction table

Malfunction:	Possible cause	Corrective action	Execution
Delivery rate too low	Air filter soiled	Clean or replace filter cartridge	Operator
	Pressure line leaky	Eliminate leakage	Specialised staff
	Speed too low	Correct speed (refer to Tab. 2)	Operator
Abnormal noise emission	RKL 160 is badly aligned	Align the RKL 160 precisely.	Specialised staff
	Bearing defective	Replace bearing	Manufacturer
	Rotor vanes generate knocking noise due to excessive wear.	Replace rotor vane	Specialised staff
	Wrong speed	Maintain speed range	Operator
	Foreign bodies in the RKL 160	Remove foreign matter. Flush out the RKL 160.	Specialised staff
	Final pressure too high	Adhere to permissible final pressure (refer to Tab. 2)	Operator
Compressed air temperature too high	Head loss in suction system too high	Clean or replace filter cartridge	Operator
	Final pressure too high	Adhere to maximum final pressure (refer to Tab. 2) Check pressure line for clogging	Specialised staff
	Wrong speed	Maintain speed range	Operator
	Pressure gauge defective	Replace pressure gauge	Specialised staff
	Suction filter contaminated	Clean filter element	Operator
Operating pressure is not attained	Wrong speed	Maintain speed range	Operator
	Pressure gauge defective	Replace pressure gauge	Specialised staff
	Leakage in the pressure line	Eliminate leakage	Specialised staff
Power requirement too high	End pressure too high	Adhere to permissible final pressure (refer to Tab. 2)	Operator
	Shut-off valve not fully open	Fully open shut-off valve	Operator
	Speed too high	Correct speed (refer to Tab. 2)	Operator
	Pressure gauge indicates incorrectly	Replace pressure gauge	Specialised staff
Safety valve blows off	Closed valves in the pressure line	Open valves	Operator
	Pressure line clogged	Eliminate clogging	Operator

Tab. 5: Malfunction table

9 Spare parts

We recommend stocking a service package as well as a suction filter cartridge.

The service package comprises all wear parts that are required for a normal repair.

Customer Service

In case of queries regarding the product, spare part orders, repairs, replacement RKL 160 and dispatch of fitters, please contact our customer service: Phone: +49 (0)7623 71741-0

Spare and wear parts

Service package	990 028-SP
Filter cartridge to suction air filter	432 096-00

10 Decommissioning and disposal

A RKL 160 that is no longer usable should not be recycled as complete unit, but disassembled into individual components and recycled according to material types. Non-recyclable materials have to be disposed of in an environmentally compatible manner.

- Prior to decommissioning and disposal of the RKL 160, it must be completely separated from the surrounding units.
- The disassembly and disposal of the RKL 160 may only be carried out by specialised staff.
- The RKL 160 has to be disposed of in accordance with the respective country-specific regulations.

Index

Index

A		M	
Acceptance	9	Maintenance	23
C		Maintenance	15
Cleaning		Maintenance schedule	23
RKL 160	24	Maintenance work	24
Components, moving	13	Malfunction table	26
Compressed air	13	Malfunctions	25
Compressed air	13	O	
Contact person	8	Occupational safety	11
Cooling	18, 24	Operating instructions	5
Copyright protection	7	Operating personnel	10
Customer Service	8	Operation	14, 21
D		Operator	9
Danger of burns	11	P	
Danger pictogram	11	Personnel	
Danger pictograms	11	Trouble shooting	25
Dangers	11	Protective equipment	10, 23
Design	17	R	
Disposal	27	Recommissioning	25
Drives	19	S	
F		Safety	9, 25
Function	18	Safety notes	23
I		Signposting	13
Improper operation	12	Spare parts	8, 27
Inspection		Specialists	10
30/38 rotor vane	22	Start-up	14, 21
during operation	21	Storage	20
Non-return valve	21	Suction air filter	24
prior to initial start-up	21	Switching off	21
Safety valve	22	Symbols in the instructions	6
Instructions	10	T	
Intended use	9	Technical data	16
Intended use	9	Transport	14, 20
L		Trouble shooting	15
Lengthy standstill	24	W	
Liability	7	Warranty	7, 8
Lubrication	18		

